

Exhibit Rules AND Regulations

These rules are based on industry standards, physical limitations of the exhibit hall and the needs of the Texas Woodworking Show. Their intent is to ensure each exhibiting organization, regardless of size, an equal opportunity, within reason, to gain access to the attending audience while providing an opportunity to explore new and creative marketing techniques. The underlying responsibility is that each exhibitor act as a “good neighbor.”

GENERAL GUIDELINES



Show Management shall make all final determinations as to which rules are being violated and it shall be the responsibility of Show Management to review all exhibits and enforce the rules of the exposition. Any exhibitor who is unsure of the interpretation of any rule or who may be in violation of rules is responsible for notifying Show Management in advance for further clarification.

Responsibility lies with the individual exhibiting organization to comply with all rules and regulations as stated by Show Management in the exhibit space contract, Exhibitor Manual, *Exhibitor Update* or other regulations and communications. Any request made by Show Management to bring a display into compliance will be respected and any changes to exhibit structure or display will be the financial responsibility of the exhibitor.

Exhibitors will be notified by Show Management if found in violation of any rules or regulations. If after this first warning, an exhibitor fails to comply with rules involving sound, lighting or multimedia, management will discontinue electrical service to the offending apparatus for a time period deemed appropriate. If electrical service is restored and a second warning is required, electrical service will be discontinued to the apparatus for the remainder of the conference. Should a second warning be required to correct any rules or regulation the exhibitor will lose seniority for the next two expositions.

ADVERTISING

The following rules apply to all future exhibits.

- Exhibitors are prohibited from showing or advertising products or services which in the opinion of Show Management are primarily aimed at other exhibitors.
- Exhibitors are prohibited from distributing at the convention center advertising or promotional material for entities other than the registered exhibitor unless special permission is obtained from Show Management (e.g., for combined booth space of small exhibitors.)
- Exhibitors are prohibited from any form of advertising or solicitation at the convention center outside of the exhibit booth space and from door drops or

advertising signage at Show Management-contracted conference hotels, without the advance written permission of Show Management.

AISLES

All aisle space belongs to the Exposition. No exhibit or advertising will be allowed to extend beyond the space assigned to the exhibitor. Booth representatives including models, demonstrators and actors in costume must remain in their own exhibit space throughout the show. They are not permitted in the aisles, other exhibitors' booths or public spaces. Any demonstration or activity which results in the obstruction of aisles or prevents ready access to neighboring exhibitors' booths shall be suspended for any period specified by Show Management.

AMERICANS WITH DISABILITIES ACT

All exhibiting organizations are required to be in compliance with the American with Disabilities Act (ADA) and are encouraged to be sensitive, and as reasonably accommodating as possible, to attendees with disabilities. Information regarding ADA compliance is available from the U.S. Department of Justice ADA Information Line (800-514-0301) and from the web site www.usdoj.gov/crt/ada/infoline.htm

Universal Access and ADA Accommodations—Exhibit Design

Exhibits are public accommodations under the Americans with Disabilities Act (ADA), and each exhibitor is responsible for ensuring that show attendees who have disabilities have access to all of the demonstrations, information, contests, giveaways, or other services offered at a booth.

Please see accompanying guidelines.

ANIMALS

Live animals are prohibited in exhibit space.

BALLOONS

The display and distribution of balloons will not be allowed at any time within the exhibit hall. Balloons

create many housekeeping problems and are particularly detrimental to the fire detection systems installed in the exhibit hall. Their use is strictly prohibited.

CRATE STORAGE

Empty crates, boxes, skids, etc. that exhibitors have labeled “Empty” will automatically be removed from exhibitors’ booths, stored and returned at the conclusion of the exposition. “Empty” stickers will be available from the official drayage contractor. There is no charge for this service.

DAMAGE TO PROPERTY

Exhibitors are responsible for damage to uncrated or improperly packed shipments, concealed damage, loss or theft of material after delivery to booth or before material is picked up for return movement. It is expressly understood that the exhibitor will make no claim of any kind against Show Management for any loss, damage or destruction of goods, nor for any damage of any nature to this business by reason of the failure to provide space for any exhibit or the removal of the exhibit.

DISPOSAL OR STORAGE OF PACKING MATERIALS

Special care will be necessary in unpacking merchandise for display. Loose cardboard cartons will not be accepted for storage unless they are knocked down flat and securely tied into bundles and properly tagged.

Be sure to remove all old labels first. It is suggested that small crates be nested in larger ones to reduce the number of pieces to be stored and thereby hasten their return. No boards or skids will be accepted for storage unless securely tied into bundles and tagged. Materials not in accord with these regulations will be considered refuse and will be disposed of by the cleaners.

No Storage of Any Kind Will Be Permitted Behind Your Display.

All combustible materials, which are not an integral part of the display, must be removed each night unless stored in a metal container. However, to facilitate repacking merchandise at conclusion of the exhibit, some exhibitors have found it convenient to remove knocked down cartons to their cars and hotel rooms for ready access.

EARLY DISMANTLING

No exhibitor will be allowed to dismantle any portion of their exhibit prior to the end of exhibit hours on the final day of exhibits. This is a discourtesy to those attending the Show and to your neighboring exhibitors. Exhibitors who dismantle prior to the closing of the show will forfeit accrued seniority for the next two Exhibitions.

FOOD SERVICE

Food and beverage service in your assigned booth space may be allowed if approved in advance by Show Management. All requests must be submitted in writing 60 days prior to the show opening. Requests to serve items which detract from the exhibit’s professional appearance will not be allowed or approved.

LIGHTING

No lighting, fixtures, lighting trusses or overhead lighting are allowed outside the boundaries of the exhibit space. Lighting should be directed to the inner confines of the booth space. Lighting should not project onto other exhibits or show aisles. Lighting which is potentially harmful, such as lasers or ultraviolet lighting, will not be permitted. Lighting that spins, rotates, pulsates and other specialized lighting effects should be in good taste and not interfere with neighboring exhibitors or otherwise detract from the general atmosphere of the event. Exhibitors intending to use light systems should submit drawings to Show Management for approval.

MULTIMEDIA

Any multimedia display (video wall, video projection, animatronics, robotics, etc.) which is deemed in violation of the Sound and Lighting regulations by Show Management will not be allowed.

MULTI-STORY EXHIBITS

In most facilities, multi-story exhibits require prior approval by the exhibit facility and/or relevant local government agencies because it is deemed to be a “structure” for building purposes. Often structural and/or fire regulations exist which dictate booth construction. Exhibitors utilizing this type of structure should seek guidance from Show Management prior to installation of multi-story exhibits. All requests must be submitted in writing 60 days prior to the show opening.

NOISE LEVELS IN DISPLAYS

Exhibits which include the operation of musical instruments, radios, sound projection equipment, public address systems or any noisemaking machines must be conducted or arranged so that the noise resulting from the demonstration will not annoy or disturb adjacent exhibitor and their patrons, nor cause the aisles to be blocked. Operators of noisemaking exhibits must secure approval of operating methods before the exhibits open. Noise levels must be held to an 80-decibel maximum at all times. Show Management will monitor the 80-decibel regulation on-site. If an exhibitor is in violation of the 80-decibel regulation, they will receive one warning. If the exhibitor continues to operate noisemaking exhibits in excess of 80-decibels after the first warning, Show Management reserves the right to cut the power of the offending mechanism, or otherwise ensure the noisemaking mechanism is shut off.

BOOTH CONFIGURATIONS

TEXAS 2007 WOODWORKING SHOW FEATURING THE CABINET CONFERENCE

Linear/Standard Booth **DEFINITION:** Exhibit consisting of one or more standard units in a straight line.

HEIGHT

Exhibit fixtures, components and identification signs will be permitted to a maximum height of 8'3" (2.5m).

DEPTH

All display fixtures over 4'0" (1.22m) in height and placed within 10 lineal feet (3.05m) of an adjoining exhibit, must be confined to that area of the exhibitor's space which is at least 5'0" (1.52m) from the aisle line for those exhibits with 14'0" (4.27m) depth or more.

IMPORTANT

Space dimensions shown on floor plan are from center line of booth equipment, such as side rails and/or back drape. Exhibit structures must be constructed to allow sufficient tolerance on each side for this equipment and for utility service at rear of booth.

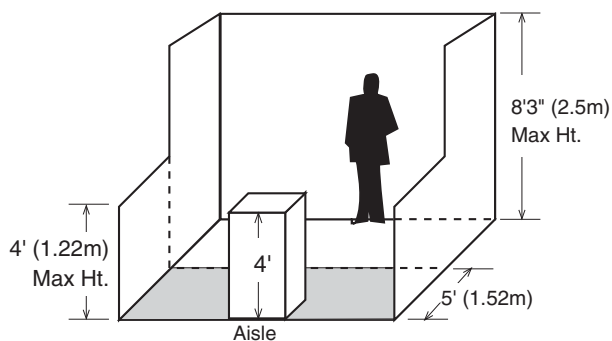

Display fixtures over 4' (1.22m) must be confined to that area of the booth that is at least 5' (1.52m) from the aisle line.

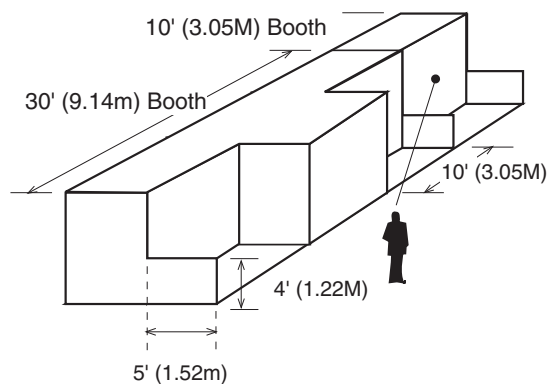
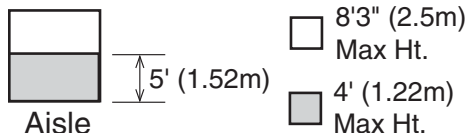

Perimeter Booth **DEFINITION:** Standard booth located on the outer perimeter aisle of the exhibit floor.

HEIGHT

Exhibit fixtures, components and identification signs will be permitted to a maximum height of 12' (3.66m) in perimeter wall booths.

DEPTH

All display fixtures over 4'0" (1.22m) in height and placed within 10 lineal feet (3.05m) of an adjoining exhibit, must be confined to that area of the exhibitor's space which is at least 5'0" (1.52m) from the aisle line for those exhibits with 14'0" (4.27m) depth or more.

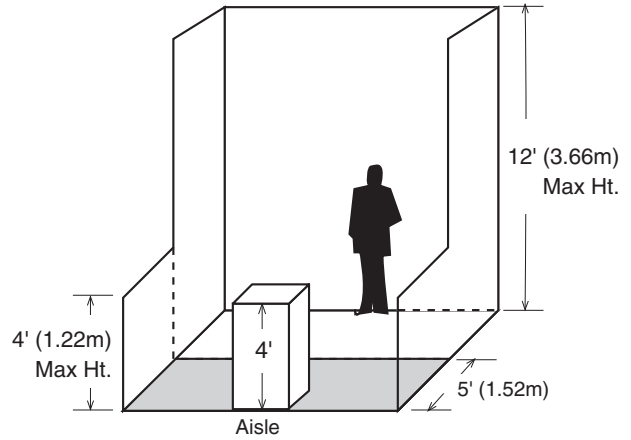

Display fixtures over 4' (1.22m) must be confined to that area of the booth that is at least 5' (1.52m) from the aisle line.

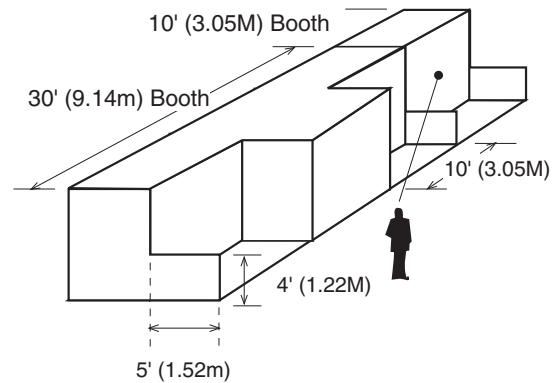
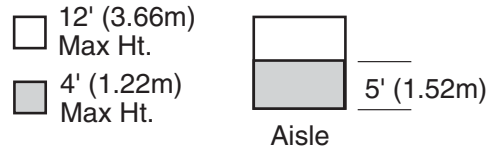

Peninsula Booth **DEFINITION:** Exhibit which occupies both corners at the end of a row of standard booths with an aisle on three sides. A Peninsula Booth is a minimum 20' x 20' in size.

HEIGHT

Exhibit fixtures, components and identification signs will be permitted to a maximum height of 16'0" (4.88m).

DEPTH

All display fixtures over 4'0" (1.22m) in height and placed within 10 lineal feet (3.05m) of a neighboring exhibit, must be confined to that area of the booth that is at least 5'0" (1.52m) from the aisle line to avoid blocking the sight line from the aisle to the adjoining booth.

STRUCTURAL INTEGRITY

All multi-story exhibits, regardless of whether people will occupy the upper area or not, and all exhibit fixtures and components exceeding 12'0" (3.66m) in height must have drawings available for inspection by exposition management, the installation and dismantling contractor, the exhibitor and governmental authority during the time the exhibit is being erected, exhibited and dismantled at the show site that include a signature or stamp of a reviewing structural engineer indicating that the structure design is properly engineered for its proposed use, and a signature of an authorized official of the exhibit building company indicating that the structure is built in compliance with the details and specifications set forth on the drawings. Signs must also be posted indicating the maximum number of people the structure will accommodate.

IMPORTANT

Peninsula booths are "faced" towards the cross aisle. Any portion of the exhibit bordering another exhibitor's booth must have the back side of that portion finished and must not carry identification signs or other copy that would detract from the adjoining exhibit.

Exhibitors are cautioned when installing a display with a ceiling or second level to check with the local fire department to ensure that their display meets with the necessary fire safety precautions involving smoke alarms, fire extinguishers, sprinkler systems, etc.

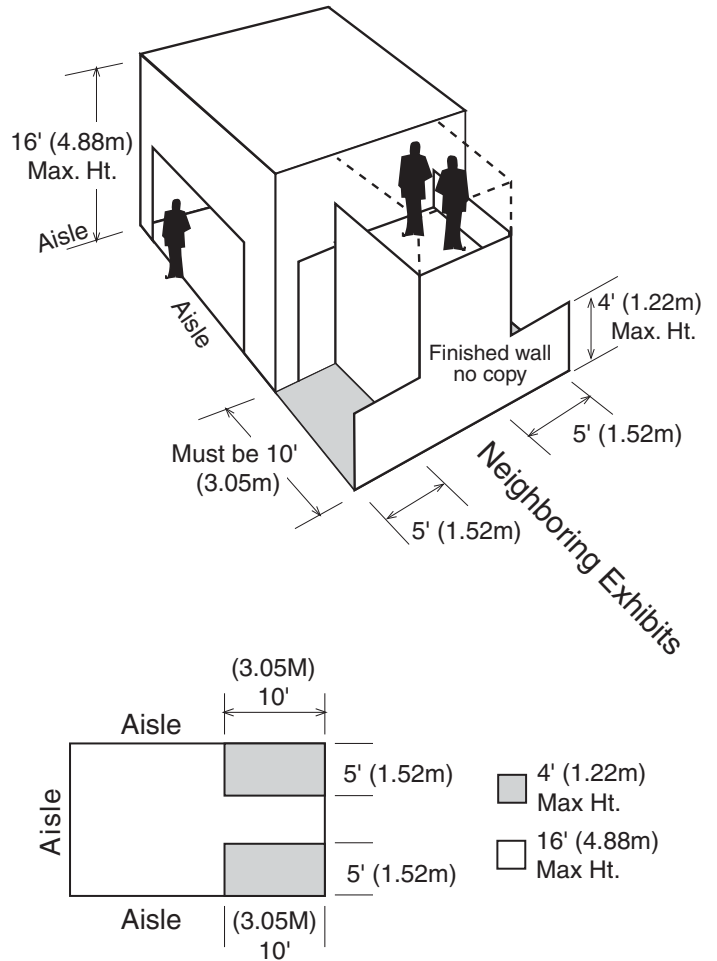

Island Booth **DEFINITION:** Exhibit with aisles on all four sides. An Island Booth is a minimum 20' x 20' in size.

HEIGHT

The entire cubic content of the space may be used up to a maximum allowable height as determined by the exhibit facility structure.

DEPTH

Because an island booth is automatically separated by the width of an aisle from all neighboring exhibits, full use of the floor plan is permitted.

STRUCTURAL INTEGRITY

All multi-story exhibits, regardless of whether people will occupy the upper area or not, and all exhibit fixtures and components exceeding 12'0" (3.66m) in height must have drawings available for inspection by exposition management, the installation and dismantling contractor, the exhibitor and governmental authority during the time the exhibit is being erected, exhibited and dismantled at the show site that include a signature or stamp of a reviewing structural engineer indicating that the structure design is properly engineered for its proposed use, and a signature of an authorized official of the exhibit building company indicating that the structure is built in compliance with the details and specifications set forth on the drawings. Signs must also be posted indicating the maximum number of people the structure will accommodate.

IMPORTANT

Exhibitors are cautioned when installing a display with a ceiling or second level to check with the local fire department to ensure that their display meets with the necessary fire safety precautions involving smoke alarms, fire extinguishers, sprinkler systems, etc.

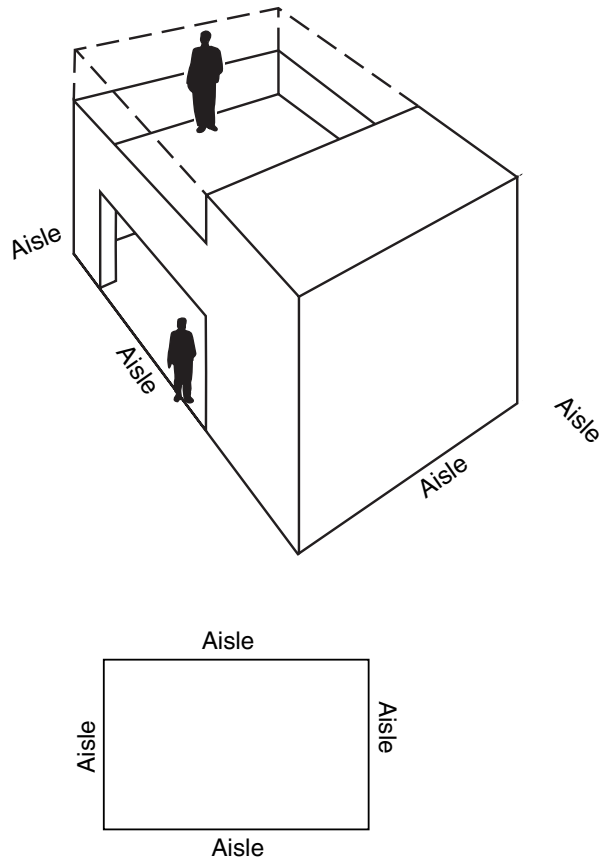

Cross-Aisle Booths: Headers & Carpet

DEFINITION: Cross-aisle headers and carpet span the aisle between exhibit booths to display a graphic identity.

HEIGHT/DEPTH

Exhibitors utilizing a minimum of 30 linear feet (9.14 meters) of space, which could be in-line, peninsula or island, facing 30' (9.14m) of exhibit space across the aisle can install a cross-aisle header with a maximum height of 12'0" (3.66m), and a minimum height of 8'0" (2.44m). The maximum width of the header from front to back is not to exceed 2'0" (.61m).

Headers and supporting structures must be located within the display so as not to interfere with any aisle traffic and must be placed a minimum of 2'0" (.61m) from the front line. They must be a minimum of 10'0" (3.05m) from any adjoining exhibit. For the purpose of safety or installation, headers may be suspended from the ceiling structure of the facility

Overhead cross-aisle headers are for the purpose of displaying the corporate name, identification or logo only. Graphics are permitted on the two sides of the sign (front/back) facing the main aisle. No graphics are allowed on any other portion of the header structure.

Cross-aisle headers, whether supported on structures or hung, may not be located as to block aisle designation signage. Show Management may request a relocation or removal of any cross-aisle headers that, in management's opinion, do not comply with all requirements of this section.

CARPET

Carpet may be installed to replace the official show aisle carpet to connect cross-aisle booths. This carpet must be of solid color and cannot contain any copy, graphics, or logos. This carpet may not be padded in any way to create obstructions or to restrict ADA accessibility.

IMPORTANT

All exhibitors who qualify and wish to use cross-aisle carpet or header in the design of their display must submit a plan to Show Management at least 60 days prior to the move-in date of the event.

Hanging Signs

DEFINITION: An exhibit component suspended above or displayed on an exhibit for the purpose of displaying graphics or identification.

HEIGHT

Peninsula, Island and Cross-Aisle Booth Configurations are the only booths that are permitted to display a hanging sign. Hanging identification signs and graphics will be permitted to a maximum height of corresponding booth configuration regulations, provided written approval is received from exposition management.

STRUCTURAL INTEGRITY

All hanging signs must have drawings available for inspection by exposition management, the installation and dismantling contractor, the exhibitor and governmental authority during the time the component is being hung, suspended and removed at the show site that include a signature or stamp of a reviewing structural engineer indicating that the stress points for hanging the sign have been properly engineered, and a signature of an authorized official of the exhibit building

company indicating that the structure is built in compliance with the details and specifications set forth on the drawings. (Note: Exhibitors are encouraged to use lightweight materials in the construction of a hanging sign to eliminate excessive stress to the facility ceiling structure.)

APPROVAL

All sign requests must be submitted with floor plans or diagrams in writing to Paul Graller, Exposition Manager, Hall-Erickson, Inc., 98 E. Naperville Road, Suite 201, Westmont, IL 60559-1559. All sign requests must be received 60 days prior to event. Signs not approved in advance will not be hung.

IF YOU DESIRE TO HANG ANY SIGNS OR OTHER MATERIALS ABOVE YOUR EXHIBIT AND IT WILL UTILIZE ANY OF THE CEILING STRUCTURES IN THE CONVENTION CENTER, PLEASE REVIEW THE HANGING SIGN REQUIREMENTS IN THIS MANUAL.

Canopies and Ceilings

DEFINITION: Exhibit component supported over an exhibitor's space for decorative purposes.

HEIGHT

Canopies, false ceilings and umbrellas will be permitted to a height that corresponds to the height regulation for the appropriate exhibit configuration of which they are a part. For example, canopies will not exceed 8'3" (2.5m) in height in a standard booth configuration. Furthermore, the canopy or false ceiling will not exceed 1'0" (30cm) in depth and cannot be used for identification or display purposes.

DEPTH

Canopies may extend out to the aisle line and up to the booth line on either side of an exhibitor's space providing that the support structure will not exceed 3" (7.62cm) in width when placed within 10 lineal feet (3.05m) of an adjoining exhibit and not confined to the area of the exhibitor's space which is at least 5'0" (1.52m) from the aisle line. Furthermore, canopies, false ceilings or umbrellas will not be used for identification or display purposes except as would normally be allowed for any exhibit component within the regulations set forth for the exhibit configuration.

IMPORTANT

Exhibitors are cautioned when installing a display with a ceiling to check with the local fire department to ensure that their display meets with the necessary fire safety precautions involving smoke alarms, fire extinguishers, sprinkler systems, etc.

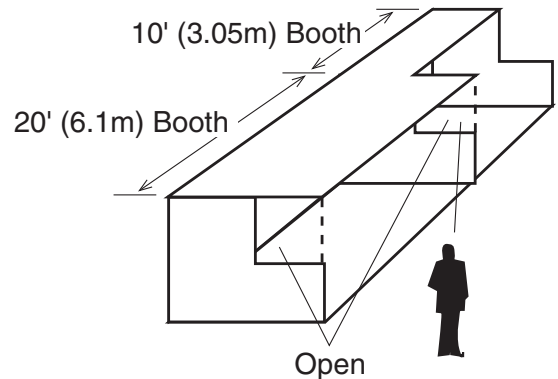
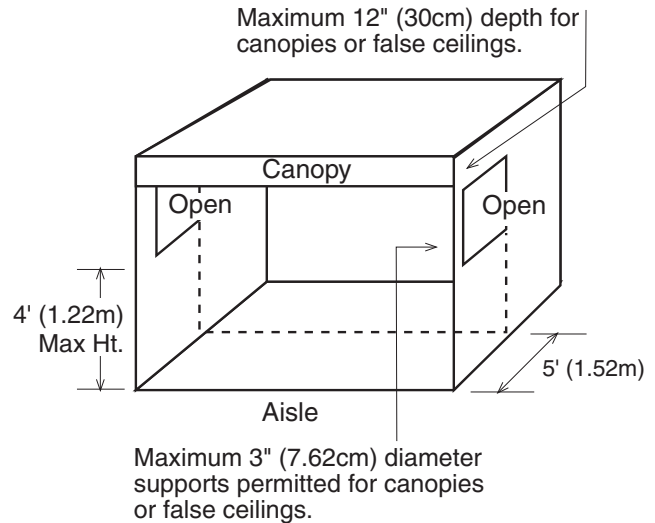

AMERICANS WITH DISABILITIES ACT GUIDELINES



Universal Access and ADA Accommodations—Exhibit Design

Exhibits are public accommodations under the Americans with disabilities Act (ADA), and each exhibitor is responsible for ensuring that show attendees who have disabilities have access to all of the demonstrations, information, contests, giveaways, or other services offered at a booth.

This brief guide suggests ways in which your booth can incorporate the goals of the universal design—making facilities accessible to all people—into its design.

GUIDELINES TO MAKE ALL BOOTHS MORE ACCESSIBLE

- Bring or rent chairs so that if you will be talking to someone who uses a wheelchair you can do so at the same eye level. A chair is also a help to people who may be ambulatory but who cannot stand for long periods to discuss your product with you.
- Mount monitors or televisions on a sturdy adjustable arm. If a video display is on a high table, be sure the mount allows you to tilt the display so people who are seated can have a clear view.
- If you are running informational videos, etc., keep the captions turned on so the deaf visitors (who may not “look” like they have a disability) can view them.
- If you are demonstrating a web site, have a lynx or other text based interface available so people can get an idea how navigable your site is using adaptive technology.
- Computer interfaces should be designed for use by any attendee. Solutions to allow universal computer access might include having different workstations at different heights; having a single workstation mounted on a height-adjustable table; or having a keyboard equipped with an extra long cable to allow a wheelchair user direct access.
- Design your walk through areas it have low, firm carpeting, 36” wide aisles, and a minimum clearance of 28” at any point. At exhibits, many wheelchair users use motorized three-wheelchairs; these require more clearance.
- All signage should be in contrasting colors, with at least 3” high.
- Ensure that if you have an inaccessible exhibit portion, all of the same demonstrations, services, etc. Are available at the ground level or in an accessible area.
- When handouts are not available in an accessible format to people who have low vision or are blind, describe all the information contained. Take the attendee’s business cards and offer to send them information in large print, on a disk in ASCII format, or via another accessible means.

AMERICANS WITH DISABILITIES ACT GUIDELINES



Daily Booth Checklist

- Floors are dry, carpet is flat, edges are flush and well secured.
- Electrical cords and computer cable are hidden and secured. Cords running under booth carpeting do not create a hazardous ridge.
- Floors are clear of trash and debris; any boxes stored under tables are pushed well to the back.
- Furniture is in its place with chairs pushed under tables.
- Chair seats are not being used for storage areas for purses or other personal belongings.
- Signage is clear and not blocked by displays.
- Displays, plants,, etc. do not block accessible routes or areas.
- Protruding objects do not extend into or block accessible routes.
- Banners, displays, etc. hang no lower than 80" from the floor where people walk.
- Hazardous areas are clearly marked from all sides.
- Alternative interfaces, adaptive equipment, and accessible workstations are working.
- Magnifiers, paper, pens, and similar aids are readily available.
- A supply of already-rolled posters is available for people who may have difficulty rolling their own.
- A stapler is available to affix business cards to information requests, contest entry forms, and other forms for people who may find writing difficult.

AMERICANS WITH DISABILITIES ACT GUIDELINES



Universal Access and ADA Compliance—Service Access

The biggest problem with disabilities—and the easiest fix—concerns attitudes. Show attendees with disabilities report their greatest frustration comes when they are either ignored by booth staffers or when they are showered with extra, patronizing attention. Below are some tips to help your booth staffers take a “person first” attitude and interact positively with all clients.

- When talking about people, use “person first” terminology. For example, refer to “children with disabilities” not “disabled children.”
- Talk directly to the customer, not to an aide or interpreter. Remember, it is the customer who is interested in your products and services.
- Keep several pads and pens handy at places throughout the Booth so that you do not have to waste time hunting around if you need them for communication.
- Keep a simple hand or sheet magnifier on hand to help people with low vision follow when you are describing literature that is not in large print.
- Don’t be afraid to use common expressions. It is perfectly fine to say “let me show you our product” to someone who is blind.
- Honor a person’s private space. Do not move canes, crutches, walkers, or other mobility aide “out of the way.” Do not hold, push, or touch a person’s wheelchair unless asked. Don’t “help” a person by touching, guiding, or leading them unless asked.
- Similarly, if you will be “swiping” a customer’s badge, ask before reaching for it.
- If you are asked to guide someone who is blind, offer the person your elbow and let the person follow you. Announce any turns, steps, or other obstacles you are approaching. If someone joins or leaves the group, announce the fact so your customer knows who is involved in the conversation.
- Do not play with or pet guide dogs or working animals, no matter how attractive. They are “on duty” and it can put their owners in danger when they are distracted.
- Be professional. People with disabilities who are attending the exhibits are doing so because they are librarians, directors, trustees—in short, because they are interested in your products. Maintain a professional tone and discuss their professional needs.

When in doubt, ask! Your customer knows whether or not he or she can hear your demonstration, move through your booth, or read your handouts. Your customer is also best situated to tell you how to accommodate his or her need. Be flexible, courteous, and willing to try, and you will go a long way toward winning a new client.